



ADK-1584 Quick Start Guide –  
HI-1584 Transceiver  
Demonstration Board

August 2017

**REVISION HISTORY**

<b>Revision</b>	<b>Date</b>	<b>Description of Change</b>
QSG-1584 Rev. New	05-18-17	Initial Release
Rev. A	08-01-17	Add additional descriptive detail. Add Direct Coupled board option.

## Introduction

The Holt HI-1584 is a 3.3V MIL-STD-1553 dual bus transceiver which is a pin-compatible drop-in replacement for the Data Device Corporation device, BU-67401L0C0. The ADK-1584 Signal Break-Out Board provides a dual 1553 bus interface comprised of HI-1584 transceiver, PM-DB2779 dual bus transformer and two 1553 bus connection jacks or terminals for connecting user-provided resistor dummy bus loads. The board provides a convenient way to evaluate transceiver performance and function. A signal header is provided for connecting logic-level transmit, receive and control signals.

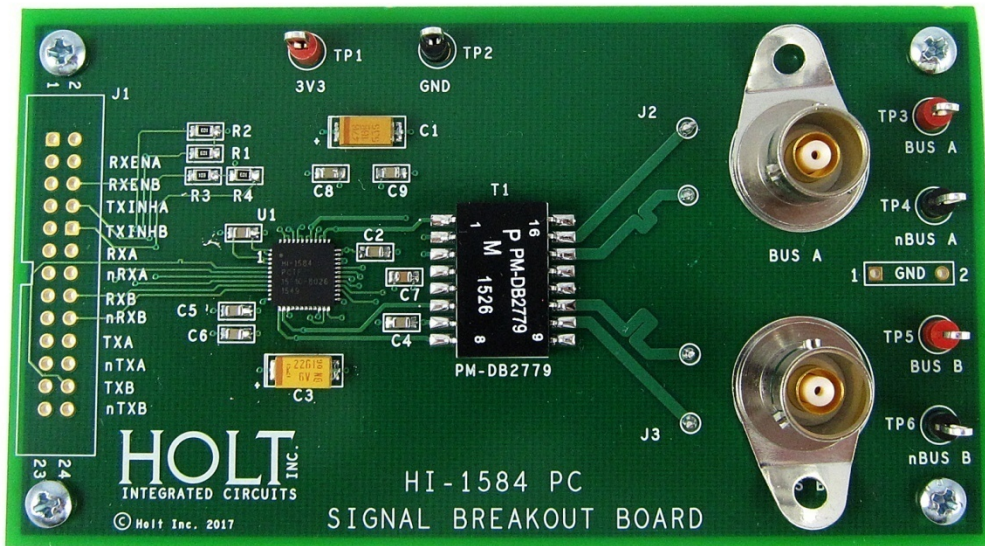

**HI-1584 Signal Break-Out Board**

## Set Up

To demonstrate the board, an external power supply providing 3.3VDC at 700mA is needed. Connect the power supply to test points 3V3 and GND along the top edge of the board. Power and GND can also be provided through pins 1-2 of logic-level signal interface header J1.

## Logic Level Signal Interface Header

Dual row header J1 provides terminals for connecting the MIL-STD-1553 bus interface to an external user-provided Manchester encoder/decoder, as well as optional Transmit Inhibit and Receive Enable transceiver control signals. Digital signals appear on one row of signal header J1; the other J1 row is fully grounded. If ribbon cable is used for external hardware connection, adjacent ribbon conductors will

alternate signal – ground – signal – ground etc. to minimize signal degradation. If providing power through a ribbon cable at J1, make sure transceiver VDD pin does not sag below 3.3V while transmitting, or transmit amplitude will suffer. Ideally, the transceiver is close to the power supply output to minimize power delivery path impedance.

## Bus Receive Signal Path

A pair of 3.3V CMOS logic-level outputs provides bipolar serial signals for connecting each bus to an external user-provided Manchester decoder.

RXA and  $\overline{RXA}$  are the non-inverted and inverted receiver outputs for Bus A.

Similarly; RXB and  $\overline{RXB}$  are the receiver outputs for Bus B.

The logic-level Bus A and Bus B receiver outputs can be enabled/disabled using the transceiver RXENA and RXENB inputs. On the HI-1584 Signal Break-Out Board, the receiver enable signals are pulled-up (enabled) by default, using 10kΩ resistors R1 and R2. If desired, receive signal outputs can be disabled by presenting logic-0 at the RXENA and/or RXENB signals at the signal interface header J1.

When either receive enable input reads logic-0, the RX and  $\overline{RX}$  receive signal outputs for the respective bus remain at logic-0.

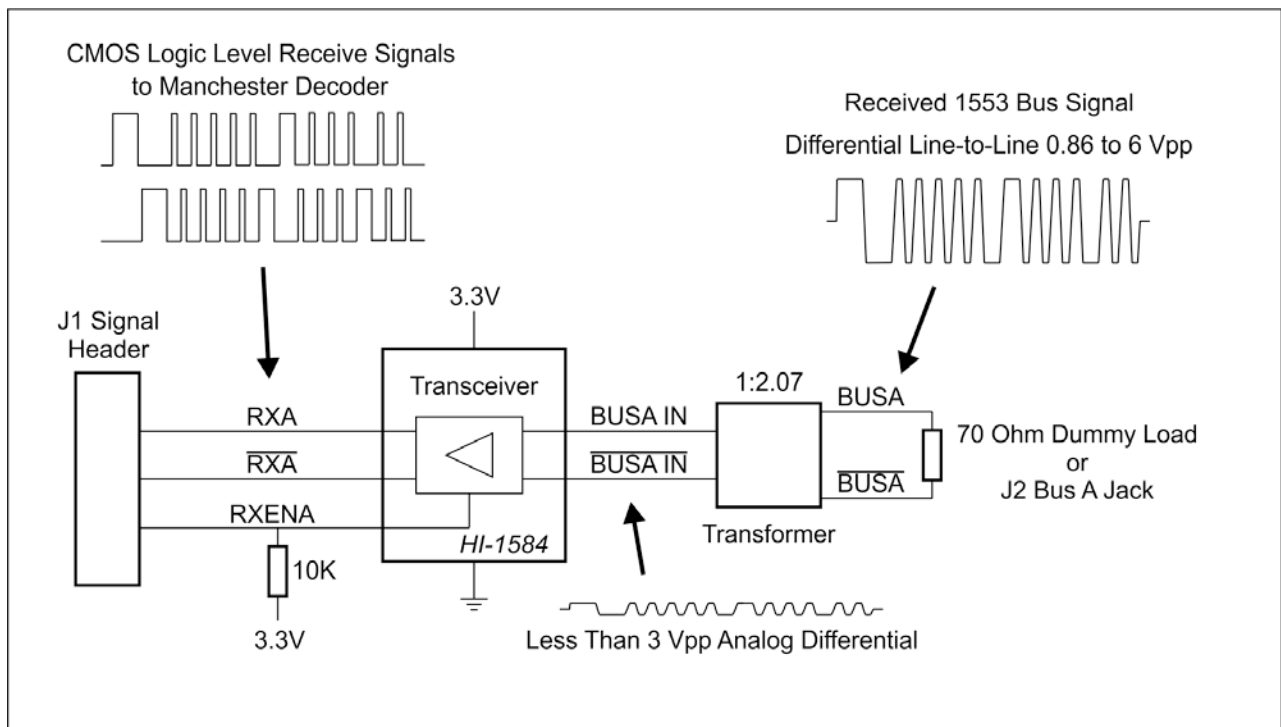

Bus A Receive Signal Path (Bus B is identical)

## Bus Transmit Signal Path

A pair of 3.3V CMOS logic-level inputs accepts MIL-STD-1553 bipolar serial signals for driving each bus from an external user-provided Manchester II encoder.

TXA and  $\overline{\text{TXA}}$  are the non-inverted and inverted transmit input signals for Bus A.

Similarly, TXB and  $\overline{\text{TXB}}$  are the transmit input signals for Bus B.

Transmit for each bus can be enabled or inhibited using the corresponding TXINH transmit inhibit signal at the signal interface header J1.

On the HI-1584 Signal Break-Out Board, both transmit inhibit signals are pulled down by default (transmit enabled) using 10k $\Omega$  resistors R3 and R4.

Bus transmit for either bus can be disabled by presenting logic-1 on the TXINHA and/or TXINHB input signal pins 8 or 10 at signal interface header J1.

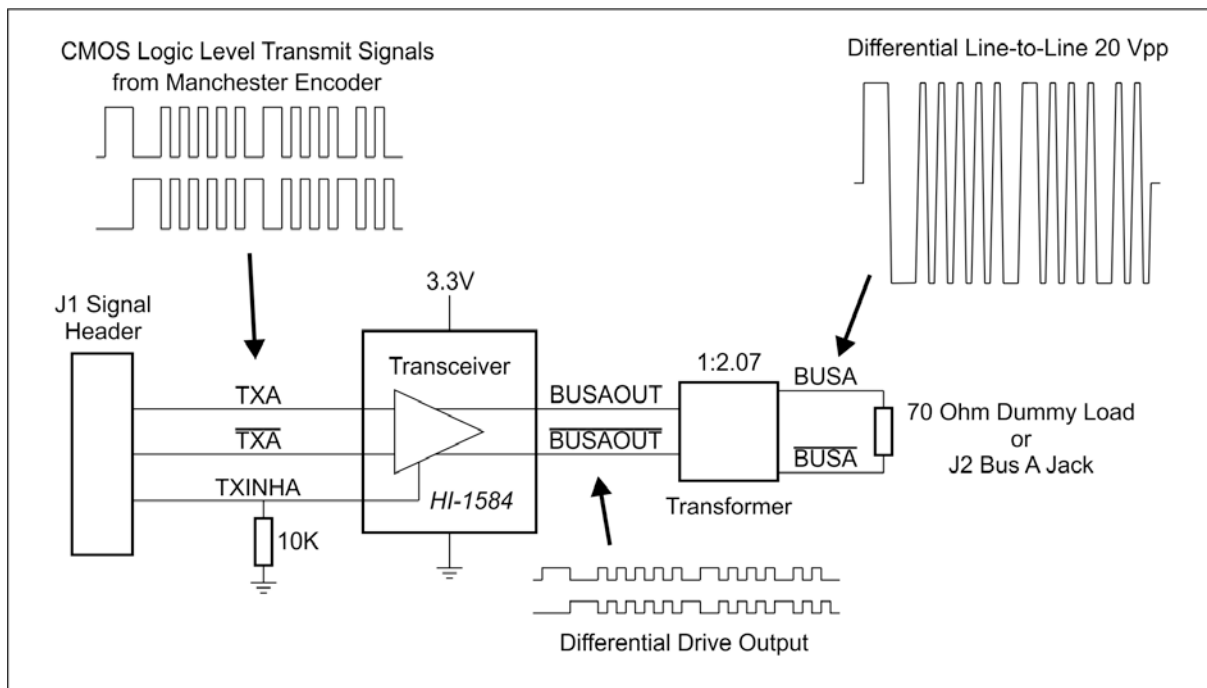

**Bus A Transmit Signal Path (Bus B is identical)**

The transmit signal path for each bus includes the bipolar TX and  $\overline{\text{TX}}$  signals generated by the external Manchester encoder. Signal quality concerns dictate that the TX and  $\overline{\text{TX}}$  signals for each bus have matched characteristics. This includes matched conductor length and impedance, matched layer-to-layer vias (or even better, no vias). It is not always possible to achieve good matching on the board layout. The result: TX and  $\overline{\text{TX}}$  switching transitions are not quite simultaneous; the TX and  $\overline{\text{TX}}$  crossover occurs early or late. Crossover should occur mid-way between ground and the 3.3V supply rail to assure

acceptable “output symmetry” or “tail-off” occurring at the end of long transmit messages. This effect is discussed at length in Holt application note AN-550.

## Direct-Coupled or Transformer-Coupled 1553 Bus Interface

The HI-1584 Signal Break-Out Board is preconfigured for transformer-coupled operation. Transformer-coupled 1553 bus interface is the predominant configuration used for terminal connection. This diagram shows a network comprised of three transformer-coupled terminals: a Bus Controller (BC) and two Remote Terminals (RTs). Transformer-coupled stub cables must be < 20 feet (6.1 meters).

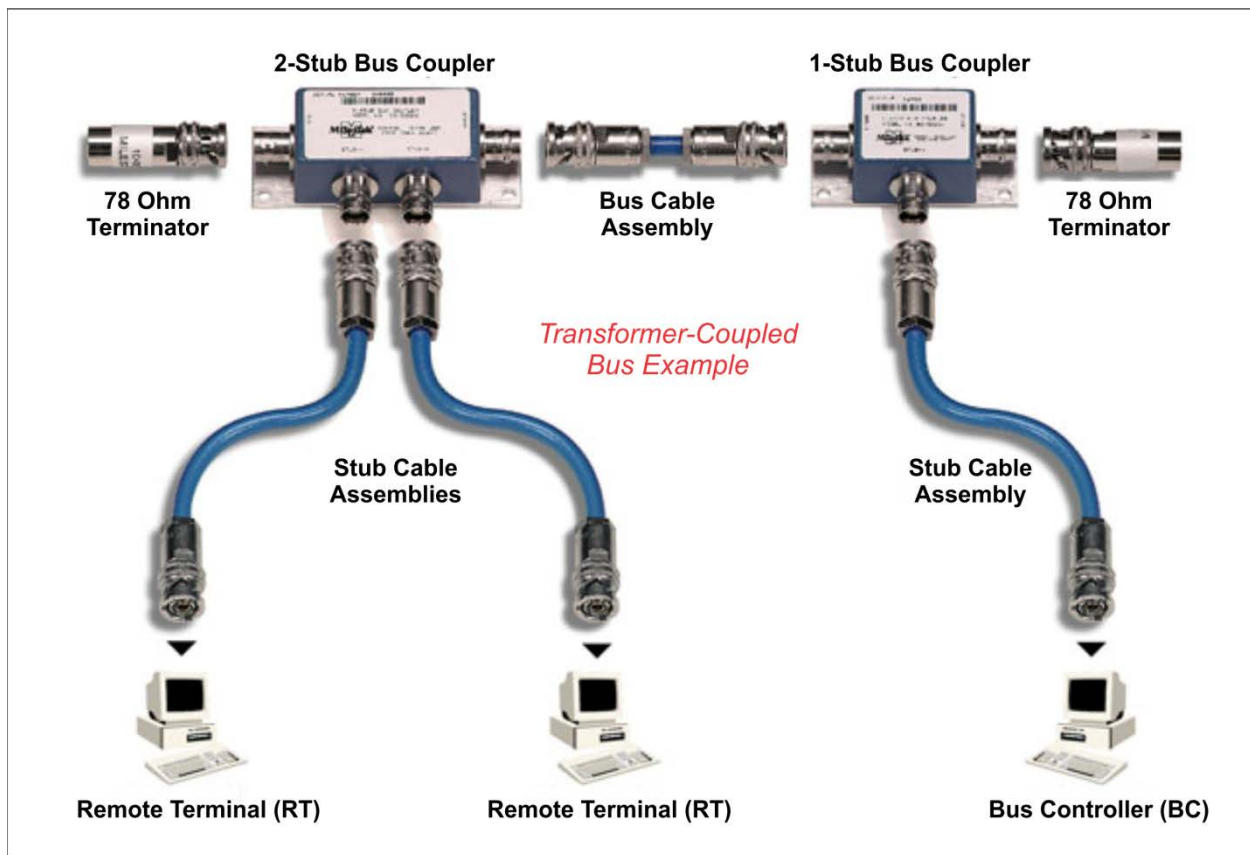

The HI-1584 Signal Break-Out Board (and user-provided protocol logic) takes the place of the BC or one of the RTs in the above diagram.

As seen above, each terminal’s stub cable connects to the 1553 bus through a “bus coupler,” which is typically an off-the-shelf hardware component comprised of coupling transformer(s) for one or more terminal stubs (each with its own pair of internal current-limiting resistors). Two bus couplers are shown above. The bus couplers have a bus connection jack at each end for serial connection into the 1553 bus structure. Each end of the bus has a 78Ω terminator.

Direct-coupled operation requires simple board modification. Two current limiting resistors are required for each bus. These are mounted on the bottom side of the board, but top-side jumper locations JP1 through JP4 short out these resistors using copper traces. For Bus A, cut shorting traces JP1 and JP2 at silkscreened hash marks. For Bus B, cut traces JP3 and JP4. Once configured for direct-coupling, the terminal no longer connects to the bus cable assembly through a Bus Coupler; it connects directly to the 1553 bus. Direct-coupled stub cables cannot exceed 1 foot (30.5 cm) length. Transformer coupled operation can be restored by soldering jumpers across locations JP1 – JP4.

Holt application note AN-550 provides additional information about the direct-coupled and transformer-coupled configurations.

### Using Dummy Bus Load Resistors

The HI-1584 Signal Break-Out Board provides jacks J2 and J3 for conventional off-board 1553 bus connection, as seen above. If desired instead, you can connect user-provided dummy load resistors which replace the stub cable assembly in the diagram and everything above it; the resistor load appears directly at the HI-1584 bus interface. The load is  $70\Omega$  1 Watt for transformer-coupled operation or  $35\Omega$  1 Watt for direct-coupled operation.

To use dummy load resistors, disconnect any cables at jacks J2 and J3. Connect the dummy load resistor across test points TP3-TP4 for Bus A. An identical resistor is connected across test points TP5-TP6 for Bus B. Only one type of bus load can be connected at a time: choose between dummy bus load resistors and external conventional 1553 bus connection using jacks J2 and J3.

### Single Scope Probe “Faux Differential” Viewing Option

When characterizing a MIL-STD-1553 terminal, most bus voltage measurements are defined as the differential line-to-line stub voltage measured across the bus side of the terminal’s isolation transformer. For the HI-1584 signal break-out board, pairs of red and black differential test points are labeled  $BUSA/\overline{BUSA}$  and  $BUSB/\overline{BUSB}$  for the two buses. An oscilloscope is easily connected to these test points labeled TP3 through TP6.

Differential line-to-line voltage measurement for Bus A can be accomplished by connecting your oscilloscope channel 1 probe to the TP3  $BUSA$  and the channel 2 probe to the TP4  $\overline{BUSA}$  test point. Then use oscilloscope built-in math function to observe “channel 1 minus channel 2”.

Comparable differential line-to-line voltage measurement for Bus B can be accomplished by connecting your oscilloscope channel 3 probe to the TP4  $BUSB$  and the channel 4 probe to the TP6  $\overline{BUSB}$  test point. Then use oscilloscope built-in math function to observe “channel 3 minus channel 4”.

If wire jumpers are added to ground bus negative test points TP4  $\overline{BUSA}$  and TP6  $\overline{BUSB}$  the user can forgo the channel 2 and channel 4 oscilloscope connections to  $\overline{BUSA}$  and  $\overline{BUSB}$ .

## QSG-1584

---

With TP4  $\overline{\text{BUSA}}$  grounded, the single channel 1 probe connection to BUSA provides true differential viewing of Bus A stub voltage.

With TP6  $\overline{\text{BUSB}}$  grounded, the single channel 3 probe connection to BUSB provides true differential viewing of Bus B stub voltage.

*This is strictly a convenience measure to be used when evaluating HI-1584 transceiver performance; the minus side of the 1553 bus stub would never be left grounded under normal circumstances for production hardware.*

### **Board Schematic Diagram and Bill of Materials**

The schematic diagram and Bill of Materials for the HI-1584 Signal Break-Out Board are on the following pages.



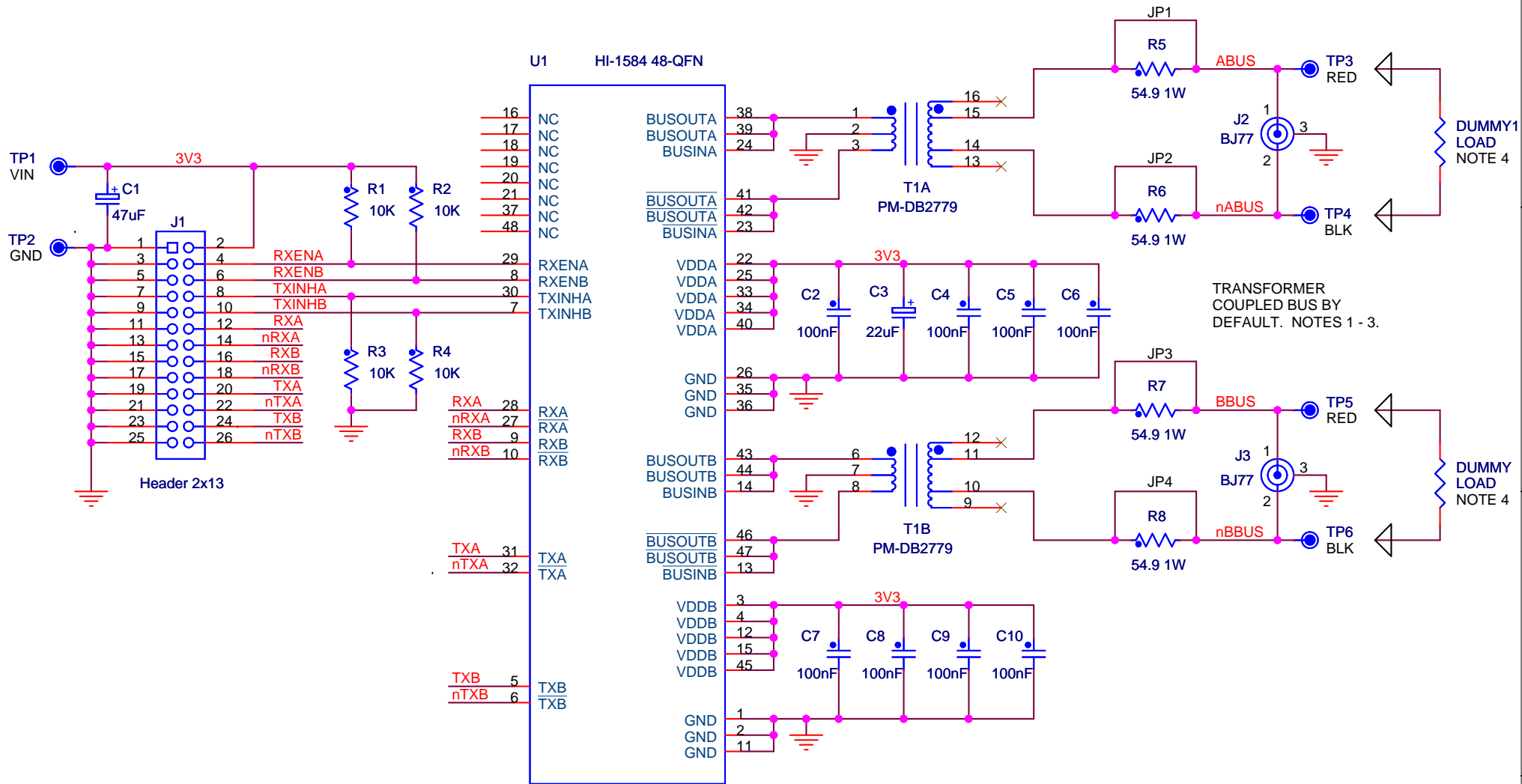

NOTES:

1. BY DEFAULT, BOARD IS SET UP FOR TRANSFORMER COUPLED OPERATION, JUMPERS JP1 - JP4 ARE COPPER TRACES.
2. RESISTORS R5 - R8 ARE USED FOR DIRECT COUPLING ONLY.
3. FOR DIRECT COUPLED OPERATION, CUT JUMPERS JP1 - JP4 AT HASH MARKS ON TOP SIDE OF THE BOARD.
4. IF BUS JACKS J2 AND J3 ARE NOT USED, RESISTOR DUMMY BUS LOADS MAY BE CONNECTED TO BUS TEST POINTS.  
USE 70 OHM 1 WATT LOAD FOR TRANSFORMER COUPLED OPERATION.  
USE 35 OHM 1 WATT LOAD FOR DIRECT COUPLED OPERATION.

<b>HOLT INTEGRATED CIRCUITS</b>		
Title		
<b>HI-1584PC SIGNAL BREAKOUT BOARD</b>		
Size	Document Number	Rev
A	HI1584PC Break Out Board	A
Date:	Friday, July 21, 2017	Sheet 1 of 1

Rev. B  
P/N HE082

Bill of Materials  
HI-1584 Signal Breakout Evaluation Board

<i>Item</i>	<i>Qty</i>	<i>Description</i>	<i>Reference</i>	<i>DigiKey</i>	<i>Mfr P/N</i>
1	1	PCB, Bare, Eval Board	N/A	-----	NewTek PCB # 13582
2	8	Capacitor, Cer 0.1uF 20% 50V Z5U 0805	C2,C4,C4,C5,C6,C7, C8,C9,C10	399-1176-1-ND	Kemet C0805C104M5UACTU
3	1	Capacitor, 47uF 20% 16V Tant SMD 6032	C1	399-9739-1-ND	Kemet T491C476M016AT
4	1	Capacitor, 22uF 20% 16V Tant SMD 6032	C3	399-3747-1-ND	Kemet T491C226M016AT
5	2	Connector 3-Lug Concentric Triax Bayonet Jack, Panel Front Mount TRB (BJ77)	J2,J3	MilesTek 10-06570	Trompeter Electronics BJ77
6	1	Header 2 x 13 with 0.1" pitch	J1 not installed	S9173-ND	Sullins SBH11-PBPC-D13-ST-BK
7	4	Resistor, 10K 5% 1/8W 0805	R1,R2,R3,R4	P10KACT-ND	Panasonic ERJ-6GEYJ103V
8	4	Resistor, 54.9 1% 1W 2512	R5,R6,R7,R8	541-54.9AFCT-ND	Vishay CRCW251254R9FKEG
9	3	Test Point, Red Insulator, 0.062" hole	(+)BusA, (+)BusB, 3V3	36-5010-ND	Keystone 5010
10	3	Test Point, Black Insulator, 0.062" hole	(-)BusA, (-)BusB, GND	36-5011-ND	Keystone 5011
11	1	IC HI-1584 48-QFN	U1	HOLT IC	Holt IC
12	1	Isolation Transformer PM-DB2779	T1	HOLT IC	Holt/ Premier Magnetics
13	4	Hookup Wire 20AWG Solid, Black Insul 1" Long	Triax jack J2 - J3 wiring	C2028B-XX-ND	General Cable C2028A.12.01
14	4	Stand-off, Threaded #4-40F, 3/4" Long Round	n/a	36-3481-ND	Keystone 3481
15	4	Machine Screw, #4-40 x 5/16"	n/a	H343-ND	B&F Supply PMS 440 0025 PH
16	4	Lock Washer, Int.Tooth #4-40	n/a	H236-ND	B&F Supply INTLWZ 004